



# FIRESTOP CENTRE

Authorised New Zealand Distributor  
Ph (09) 483 4000 www.firestopcentre.co.nz

## AGNI-Seal in 1x13mm Plasterboard Wall or 90mm Concrete/Masonry/Block Wall Threaded Steel Rod 12mm diam Max FRR -/60/60

System ID# FC891

### Step-by-step installation instructions:

1. Ensure the aperture is free from dust and debris.
2. Seal the annular gap between the service and the wall with AGNI-Seal.
3. Apply a 20mm x 20mm AGNI-Seal fillet/cone around the rod back to the wall.

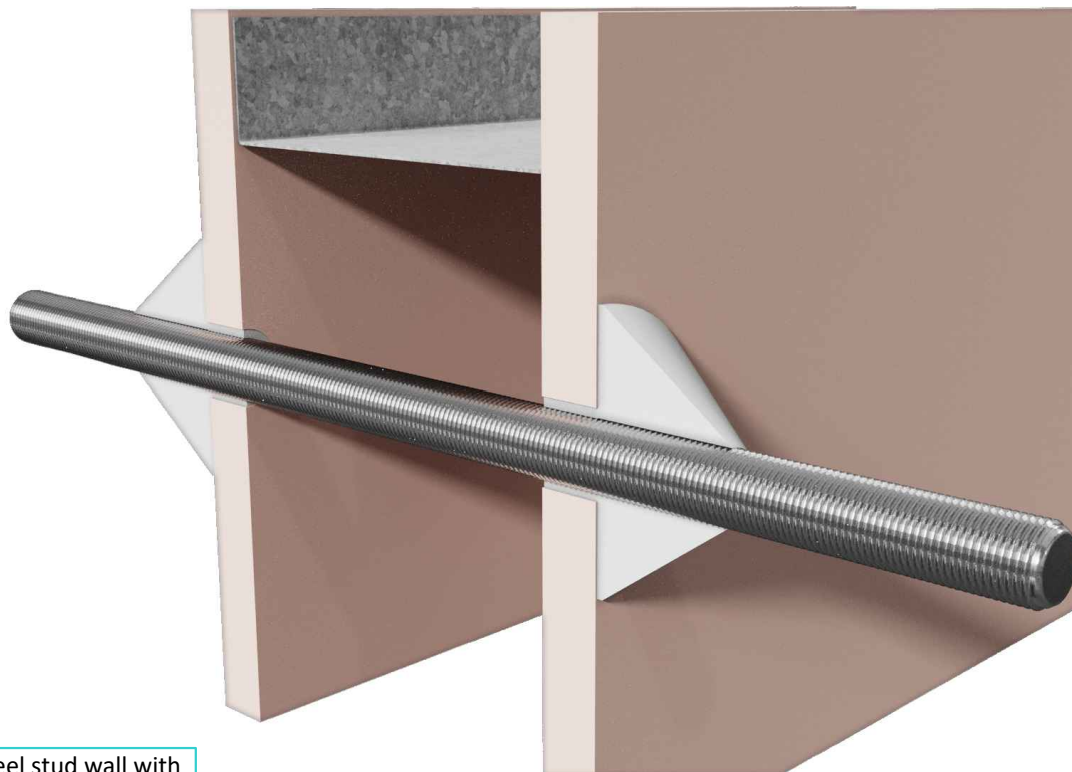

### Technical Information

Substrate	<ul style="list-style-type: none"> <li>• Min. 64mm timber or steel stud wall with a minimum of one layer of 13mm (or greater) FR plasterboard on each side, with or without insulation.</li> <li>• Min. 90mm concrete wall</li> </ul>
Service range	M12 threaded rod
Annular gap	5.4 - 6.5mm
AGNI-Products	AGNI-Seal
Protection installation	Coned - both sides of the wall

### Compliance Information

Standards	AS1530.4-2014, AS4072.1-2005
FRR/FRL	-/60/60
Reference	PF24102



**Agnitek**<sup>®</sup>  
FIRE RATED TECHNOLOGY

8 Clare St Bayswater  
VIC 3153, AUSTRALIA  
www.agnitek.com.au

### Disclaimer

Agnitek reserves the right to modify product specifications without prior notice due to its ongoing research, development & certification programme. The information in this document is provided in good faith and is intended for guidance purposes only. Any accompanying drawings are solely for illustrative purposes. Since Agnitek cannot oversee installation methods or ensure site conditions, no warranties, expressed or implied, are intended regarding the products' actual performance. We do not accept liability for any loss, damage, or injury from using this information. Please take a look at the test reports displayed on a relevant AGNI-System webpage for all compliance specifics.

Date 20.12.2024



# FIRESTOP CENTRE

Authorised New Zealand Distributor  
Ph (09) 483 4000 www.firestopcentre.co.nz

## AGNI-Seal in 1x13mm Plasterboard Wall or 90mm Concrete/Masonry/Block Wall Threaded Steel Rod 12mm diam Max FRR -/60/60

System ID# FC891

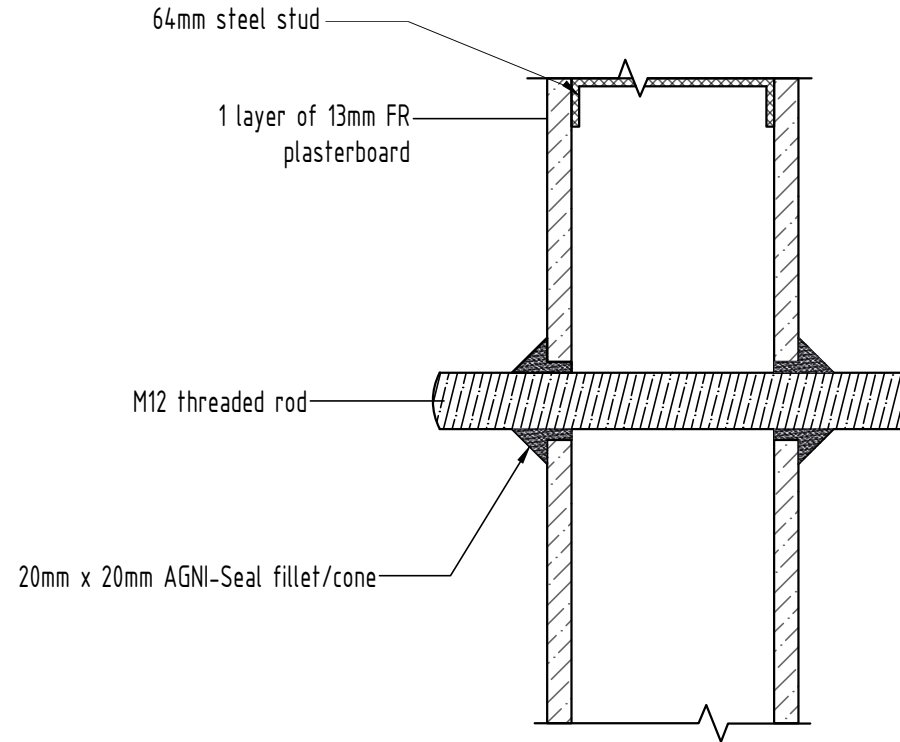

### Technical Information

Substrate	<ul style="list-style-type: none"> <li>Min. 64mm timber or steel stud wall with a minimum of one layer of 13mm (or greater) FR plasterboard on each side, with or without insulation.</li> <li>Min. 90mm concrete wall</li> </ul>
Service range	M12 threaded rod
Annular gap	5.4 - 6.5mm
AGNI-Products	AGNI-Seal
Protection installation	Coned - both sides of the wall

### Compliance Information

Standards	AS1530.4-2014, AS4072.1-2005
FRR/FRL	-/60/60
Reference	PF24102



8 Clare St Bayswater  
VIC 3153, AUSTRALIA  
www.agnitek.com.au

#### Disclaimer

Agnitek reserves the right to modify product specifications without prior notice due to its ongoing research, development & certification programme. The information in this document is provided in good faith and is intended for guidance purposes only. Any accompanying drawings are solely for illustrative purposes. Since Agnitek cannot oversee installation methods or ensure site conditions, no warranties, expressed or implied, are intended regarding the products' actual performance. We do not accept liability for any loss, damage, or injury from using this information. Please take a look at the test reports displayed on a relevant AGNI-System webpage for all compliance specifics.

Date	12.12.2024
------	------------